

Operating Instructions

Three Phase Hot Water Electric Pressure Cleaner



Operating Instructions

Electric Hot Water Pressure Cleaner

. Before attempting to operate your machine, please read all of the instructions to ensure safe and trouble free service from your machine.

Component Checklist

The following standard accessories should have accompanied your machine: -

- (1) Hose assembly;
- (2) Gun and lance assembly;

Pre-Operation Instructions

- (1) Ensure that the machine is switched off before proceeding with the following instructions.
- (2) Connect the high-pressure hose to the pump outlet.
- (3) Connect the water supply to the inlet water fitting on the pump. Ensure that the water supply is sufficient for the operation of the pump, if you are uncertain of the suitability of the water supply then refer to the recommended flow rate, which is displayed on the data plate on the pump body.
- (4) Ensure that the water inlet supply filter is not blocked due to the presence of foreign particles in the water supply. Clean the water inlet supply filter regularly to ensure smooth operation.
- (5) Check that the oil level on the pump indicates the correct level

(6) OPERATION

- (i) **Read the safety precautions sticker on your machine before proceeding to use this machine;**
 - (ii) Turn water supply ON
 - (iii) Switch machine to ON position
 - (iv) Switch the Burner to the ON position and set the thermostat to the required temperature
 - (v) Point the lance towards the object to be cleaned and depress the trigger on the gun;
 - (vi) If using a twin lance, ensure that the tap handle on the lance is on the 'off' position for optimum pressure. On this high pressure operation the water should only come out of the stainless steel high pressure jet;
 - (vii) To reduce pressure, or, operate on low pressure for detergent, open the low-pressure handle on the twin lance. If using a single lance with a Multireg nozzle, pull back the outer cover on the nozzle.
- (7) Chemical Injection Operation
- (i) Insert the filter end of the clear detergent hose into the container holding the cleaning detergent to be used and affix the opposite end to the chemical injector;
 - (ii) Turn the knob on the chemical injector anticlockwise to adjust the flow of the detergent;
 - (iii) To reduce pressure, or, operate on low pressure for detergent, open the low-pressure handle on the twin lance. If using a single lance with Multireg nozzle, pull back the outer cover on the nozzle.
- (8) To end operation
- (i) Switch the machine Burner OFF at the on/off switch;
 - (ii) Continue to run cold water through the Gun/Lance to cool the heating coil
###Continue to cool for approximately 60 seconds###
 - (iii) Switch the power point off and disconnect plug from the power point;
 - (iv) Turn the inlet water off at the tap;
 - (v) Pull the trigger on the gun to release any backpressure;

- (vi) Disconnect both the water inlet supply hose and the water outlet high-pressure hose.

Important Safety Precautions

- (1) Never direct the spray jet at any person or animal;
- (2) Never place any part of your body over the nozzles;
- (3) Never direct the spray jet towards either the machine itself or any electrical item;
- (4) After use, pull the trigger on the gun to release any backpressure;
- (5) When not in use, ensure that the machine is switched off and is disconnected from both power supply and inlet water supply;
- (6) Do not attempt any mechanical repair yourself. Should your machine require either service or repair then please contact your local Jetwave agent;
- (7) Never supply any liquid other than water to the water inlet;
- (8) Never pull on the high pressure hose if it has formed kinks or nooses;
- (9) Never drag the hose over sharp objects;
- (10) Do not attempt to disconnect either the hose or any couplings whilst there is pressure in the hose. Refer to point (4) above.
- (11) Do not operate the machine whilst on a ladder;
- (12) Never allow children to either operate or play with the machine;
- (13) The use of safety glasses is recommended when using the machine to prevent any loose particles disturbed by the high-pressure spray coming into contact with your eyes.

Tips & Hints

- (1) Regularly check the oil level in the pump. The oil level should be maintained at the level indicated on the pump.
- (2) Top up the oil in the pump when required using SAE 20W 50 oil. Never mix different grades of oil.
- (3) Use a good quality 13mm (inside diameter) water supply hose and connect to the water inlet on the pump using a hose clamp. Ensure that this connection is tight to avoid leaks.
- (4) Ensure that the tap on the water supply is fully opened before operating the machine.
- (5) Where possible, avoid the use of long extension leads as these will cause the machine to overheat and will void warranty.
- (6) After detergent use, flush the machine for a few minutes with clean water.

Burner Maintenance

- (7) The burner installed on our high pressure cleaner, runs only with Diesel. Periodically check and clean the filters and the fuel nozzle, we recommend the replacement of the same every 400 working hours.

Coil

- (8) If the coil is covered in soot, you should check the burner at the Customer Service Centre.

Trouble Shooting

The following table is provided as a general guide only. Please refer to your local Jetwave agent for service, repairs or specific advice.

Fault	Probable Cause	Possible Remedy
Pump runs normally but pressure does not achieve rated value.	Pump is sucking air.	Check that all hoses and fittings are airtight.

	Valves are worn or dirty.	Check, clean or replace.
	Unloader valve packaging worn.	Check and replace.
	Nozzle incorrect or worn.	Check and replace.
	Worn piston packing.	Check and replace.
	Dirty filter.	Check and clean.
Fluctuating pressure.	Valves dirty, worn or stuck.	Check, clean or replace.
	Pump sucking air.	Check that all hoses and fittings are airtight.
	Worn piston packing.	Check and relace.
	Dirty filter.	Check and clean.
Presence of water in oil.	High humidity in air.	Check and change oil twice as often.
	Piston packing or oil seal worn.	Check and replace.
	Water entering through breather.	Excessive water on machine.
Water dripping from pump.	Piston packing worn.	Check and replace.
	Piston guide o’rings worn.	Check and replace.
Dripping oil.	Worn oil seals.	Check and replace.
	Oil coming out of breather.	Pump oil level overfull.
Motor does not start when switched on.	Plug not well-connected or unreliable power supply.	Check plug, cable and switch.
	Earth leakage overload.	Check earth leakage.
When switched on the motor hums but does not run.	Mains voltage is insufficient.	Check adequacy of mains power supply.
Motor stops suddenly during operation.	Thermal overload tripped due to overheating.	Check mains voltage for fluctuations.
The water does not reach working temperature.	Damaged thermostat.	Replace.
	Thermostat adjusted too low.	Place the thermostat at the required temperature.
	Scale in the hydraulic system.	Contact the Maintenance Service.
	Sooted boiler.	Contact the Maintenance Service.
The boiler is smoking.	Water in the gas oil tank.	Completely drain the gas oil tank then, fill up with clean gas oil.
	Incorrect gas oil pressure.	Turn the adjusting screw until obtaining approx. 10 bar; contact the Maintenance Service.
	Electrodes improperly positioned.	Adjust the difference between the electrodes; contact the Maintenance Service.
	Fuel nozzle dirty.	Clean the fuel nozzle.

	Fuel nozzle worn out.	Replace the fuel nozzle.
	Heating coil blocked by soot.	Clean the heating coil.
	Gas oil pump dirty.	Disassemble the pump and clean the filter; contact Maintenance Service.
	Gas oil solenoid valve not working.	Replace the solenoid valve.
The burner cut out during operation.	Gas oil tank empty.	Fill up the gas oil tank.
	Water in the gas oil tank.	Completely drain the gas oil tank and fill up with clean gas oil.
	Fluxostath damaged.	Replace the fluxostath.
	Starting transformer damaged.	Replace the transformer.
	Rotation of the starting electrodes.	Set the electrodes back to their proper position; contact the Maintenance Service.
	Gas oil nozzle dirty.	Clean the nozzle.
	Gas oil nozzle damaged.	Replace the nozzle.
	Gas oil pump damaged.	Replace the gas oil pump.
	Gas oil solenoid valve damaged.	Replace the gas oil solenoid valve.

STANDARD OPERATING PROCEDURES

HIGH PRESSURE CLEANERS

SPECIAL INSTRUCTION:

1. High pressure cleaning should be carried out in an area isolated from other workers, or steps taken to prevent exposure of persons to the cleaning process.
2. Persons should not operate high pressure cleaners unless they have been instructed in the hazards and the means of safe use of the equipment.
3. All persons using high pressure cleaners are to use personal protective equipment appropriate for the task and the equipment used.



Task sequence	Identified hazards in task	Key processes to be followed	Precautions / PPE required
1. Preparation	Electric Shock Skin irritation Burns, risk of fire	Care must be taken to ensure that electric leads are kept out of water, and preferably above ground. Follow manufacture's instructions when adding cleaning agents to cleaners. Exercise caution when igniting gas or oil burners on steam cleaners.	Safety switch or RCD must be used. Hand protection must be worn. No smoking in vicinity.
2. Operation	Foreign matter in eyes Skin irritation Burns Slips and falls Noise	Water splash will contain cleaning agent and foreign matter from article being cleaned, which may splash back towards operator. Overspray and splash back will result in operator's clothing becoming wet with contaminated water from cleaner. Protect hands from hot water and heat from lance. Keep work areas clean – remove grease and other matter from floors. Larger units and steam cleaners may generate unsafe noise levels.	Wear safety goggles and/or face shield. Wet weather clothing and waterproof footwear required. Wear PVC gloves. Wear hearing protection.
3. Risks to other persons	Splashing	The distance that water will be ejected over depends on the shape and velocity of the water	Prevent unauthorised entry into are where cleaning is

jet. Exclusion of persons other than those actually involved in the cleaning task should be made to prevent injury from water and water-borne particles and cleaning agents.

being carried out.

PRECAUTIONS:

1. The following precautions should be observed when carrying out this procedure.
2. Where applicable, suitable safety and warning signs should be displayed in areas where this procedure is carried out.

Preparation	Operation	Risk to other persons
		

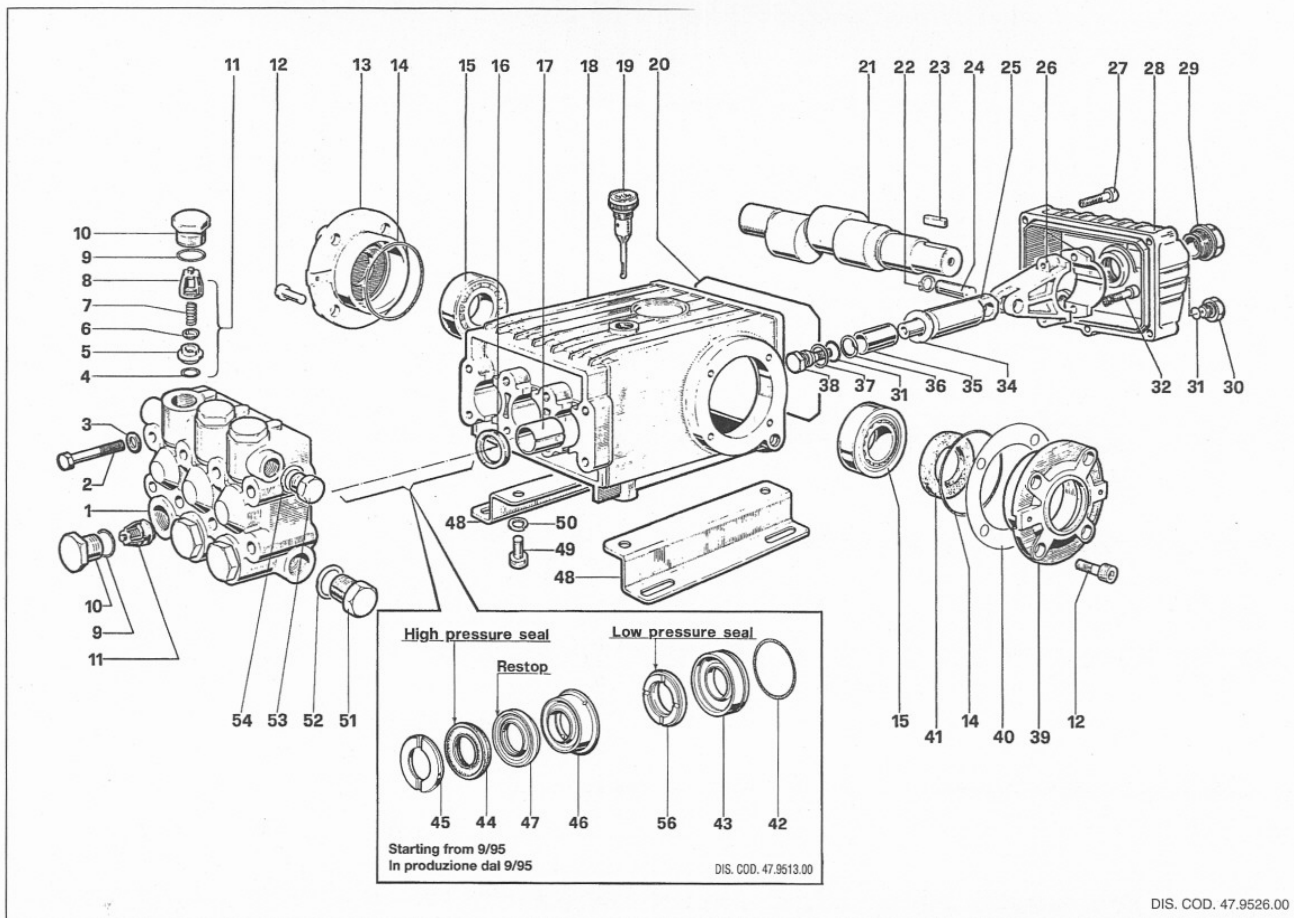

KIT N.	KIT 1	KIT 2	KIT 3	KIT 5	KIT 6	KIT 7	KIT 69	KIT 71	KIT 10	KIT 28
Positions Included Posizioni Include	4-5-6 7-8 (11)	16	41	9-10	31-34 36-37 38	45	44-47 56	46-47	42-43	42-43 44-45 46-47 56
N. pcs.	6	3	2	6	3	6	3	3	3	1

POS.	CODE CODICE	DESCRIPTION DESCRIZIONE	N. PCS.
1	47.1202.41	Testata Nichel	1
2	99.3206.00	Vite M8x70 UNI 5737	8
3	96.7020.00	Rosetta Ø 8 UNI 1736	8
4	90.3841.00	OR Ø 17,13x2,62	6
5	36.2003.66	Sede valvola	6
6	36.2001.76	Valvola	6
7	94.7376.00	Molla Ø m 9,4x14,8	6
8	36.2002.51	Guida valvola	6
9	90.3847.00	OR Ø 20,24x2,62	6
10	98.2222.00	Tappo M 24x2x16,5 spec. NK	6
11	36.7032.01	Gruppo valvola	6
12	99.3039.00	Vite M8x16 UNI 5931	8
13	47.1501.22	Coperchio carter	1
14	90.3913.00	OR Ø 67,95x2,62	2
15	***	See Table A - Vedi Tab. A	
16	90.1625.00	Anello Radiale Ø 22x32x5,5	3
17	90.9126.00	Boccola Ø 22x25x30	3
18	***	See Table A - Vedi Tab. A	
19	98.2106.00	Tappo carico olio G 3/8	1
20	90.3922.00	OR Ø 133,02x2,62	1
21	***	See Table A - Vedi Tab. A	
22	90.0557.00	Anello di fermo	6
23	***	See Table A - Ved. Tab. A	1
24	97.7380.00	Spinotto Ø 13x35	3
25	47.0503.56	Guida pistone	3
26	47.0300.01	Biella completa	3
27	99.1912.00	Vite M6x30 UNI 5931	5
28	47.1601.22	Coperchio carter	1

PUMP W916

POS.	CODE CODICE	DESCRIPTION DESCRIZIONE	N. PCS.
15	91.8375.00	Cuscinetto a rulli 32206	2
18	47.0100.22	Carter	1
21	47.0206.35	Albero semplice P. di F.	1
23	91.4878.00	Linguetta	1

POS.	CODE CODICE	DESCRIPTION DESCRIZIONE	N. PCS.
29	97.5968.00	Spia olio G 3/4	1
30	98.2041.00	Tappo G 1/4x9	1
31	90.3585.00	OR Ø 10,82x1,78	4
32	99.3099.00	Vite M8x35 UNI 5931	6
34	96.7286.00	Rosetta Ø 14x28x0,5	3
35	47.0404.09	Pistone Ø 20	3
36	90.5067.00	Anello per OR	3
37	96.7280.00	Rosetta Ø 14x18,5x0,5	3
38	47.2195.66	Vite fissaggio pistone	3
39	47.1500.22	Coperchio carter	1
40	97.5678.00	Spessore	2
41	90.1648.00	Anello radiale Ø 30x55x7	1
42	90.3616.00	OR Ø 34,65x1,78	3
43	47.0805.70	Anello di fondo Ø 20	3
44	90.2705.00	Anello tenuta H.P. seal	3
45	47.1000.51	Anello testa Ø 20	3
46	47.2169.70	Anello intermedio Ø 20	3
47	90.2704.00	Anello "RESTOP" Ø 20	3
48	47.2000.74	Piedino	2
49	99.3644.00	Vite M10x18 UNI 5931	4
50	96.7106.00	Rosetta Ø 10 DIN 7980	4
51	98.2176.00	Tappo G 1/2x10	1
52	96.7514.00	Rosetta Ø 21,5x27x1,5	1
53	98.2100.00	Tappo G 3/8x13	1
54	96.7380.00	Rosetta Ø 17,5x23x1,5	1
56	90.2710.00	Anello tenuta Ø 20 L.P. seal	3

PUMP WS152 - WS202 - W921

POS.	CODE CODICE	DESCRIPTION DESCRIZIONE	N. PCS.
15	91.8377.00	Cuscinetto a rulli 32206	2
18	47.0102.22	Carter	1
21	47.0217.35	Albero semplice P. di F. - WS152-202	1
21	47.0219.35	Albero semplice P. di F. - WS921	1
23	91.4890.00	Linguetta	1

TAB. A

AUTOMATIC PRESSURE REGULATORS REGOLATORI AUTOMATICI DI PRESSIONE

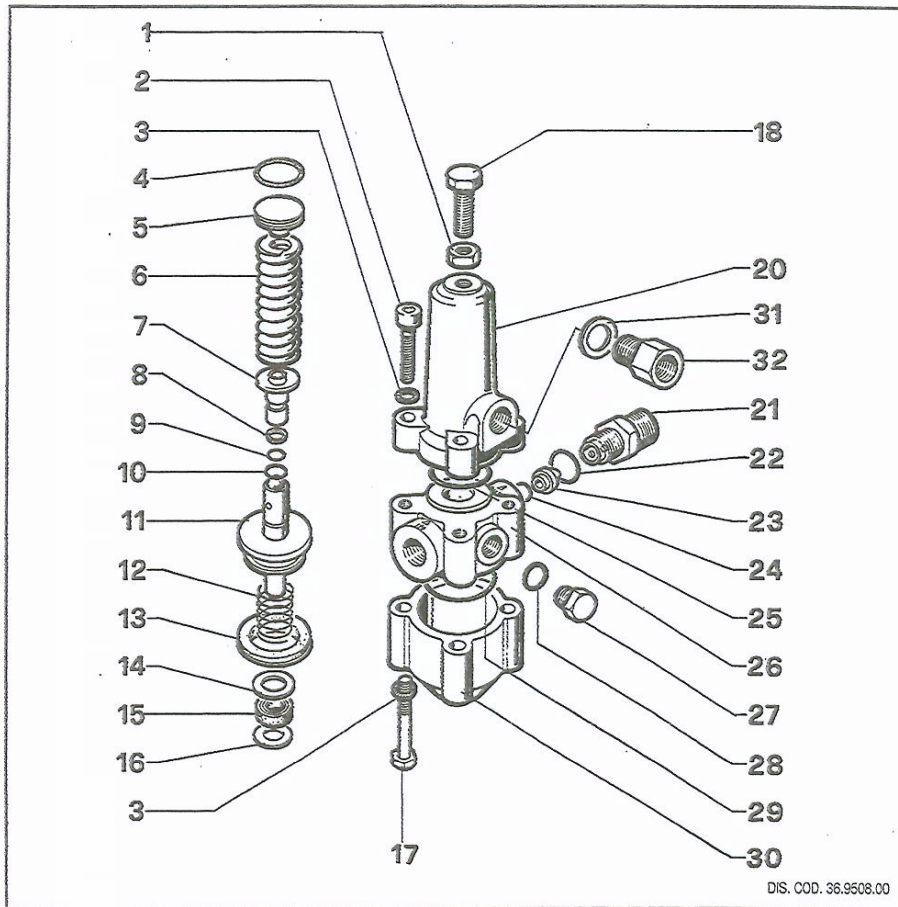

*** TAB. "A" - TABLE "A"

KIT N.	KIT 70
Positions Included	4 - 7 - 8 - 9 - 10 11 - 12 - 13 - 15 - 16
Posizioni incluse	22 - 24 - 25 - 28 - 29
N. pcs.	1

MODEL	POS.	CODE CODICE	DESCRIPTION DESCRIZIONE	N. PCS.
K 7.0 8÷11 l/min.	21	10.0078.70	Nipplo G 3/8 con foro Ø 3	1
	23	10.0076.66	Ugello Ø 2,2	1
	32	36.3117.70	Nipplo G 3/8	1
K 7.1 11÷16 l/min.	21	10.0078.70	Nipplo G 3/8 con foro Ø 3	1
	23	10.0077.66	Ugello Ø 2,5	1
	32	36.3116.70	Nipplo G 3/8	1
K 7.2 16÷25 l/min.	21	10.0160.70	Nipplo G 3/8 con foro Ø 3,25	1
	23	10.0162.66	Ugello Ø 2,75	1
	32	36.3118.70	Nipplo G 3/8	1
K 7.3 25÷41 l/min.	21	10.0161.70	Nipplo G 3/8 con foro Ø 3,5	1
	23	10.0163.66	Ugello Ø 3	1
	32	36.3119.70	Nipplo G 3/8	1

K7

POS.	CODE CODICE	DESCRIPTION DESCRIZIONE	N. PCS.
1	92.2368.00	Dado M10	1
2	99.3084.00	Vite M8x30 UNI 5931	4
3	96.7014.00	Rosetta Ø 8,4x13x0,8	8
4	90.3849.00	OR Ø 20,63x2,62	KIT 70 1
5	36.3095.70	Piattello molla	1
6	94.7466.00	Molla Ø 17x60	1
7	36.3094.66	Sede valvola	KIT 70 1
8	90.5052.00	Anello per OR	KIT 70 1
9	90.3820.00	OR Ø 9,13x2,62 - Spec.	KIT 70 1
10	90.3582.00	OR Ø 9,25x1,78	KIT 70 1
11	36.3097.02	Assieme pistoncino e sfera	KIT 70 1
12	94.7464.00	Molla Ø 17x17	KIT 70 1
13	90.2766.00	Anello tenuta Ø 40	KIT 70 1
14	96.7215.00	Rosetta Ø 13x20x2	1
15	90.2565.00	Anello tenuta Ø 10	KIT 70 1
16	90.5063.00	Anello per OR	KIT 70 1
17	99.3127.00	Vite M8x45 UNI 5737	4
18	99.3663.00	Vite M10x25 UNI 5740	1

POS.	CODE CODICE	DESCRIPTION DESCRIZIONE	N. PCS.
20	36.3090.41	Corpo valvola superiore	1
21	***	Vedi Tab. "A" - See table "A"	
22	90.3833.00	OR Ø 13,95x2,62	KIT 70 1
23	***	Vedi Tab. "A" - See table "A"	
24	90.3823.00	OR Ø 9,92x2,62	KIT 70 1
25	90.3863.00	OR Ø 28,25x2,62	KIT 70 1
26	36.3091.41	Corpo valvola centrale	1
27	98.2041.00	Tappo G 1/4x9	2
28	90.3585.00	OR Ø 10,82x1,78	KIT 70 2
29	90.3871.00	OR Ø 34,60x2,62	KIT 70 1
30	36.3092.41	Corpo valvola inferiore	1
31	96.7380.00	Rosetta Ø 17,5x23x1,5	1
32	***	Vedi tab. "A" - See table "A"	

Tav. 07

CALDAIA - BOILER - CHAUDIERE - CALDERA

V 1

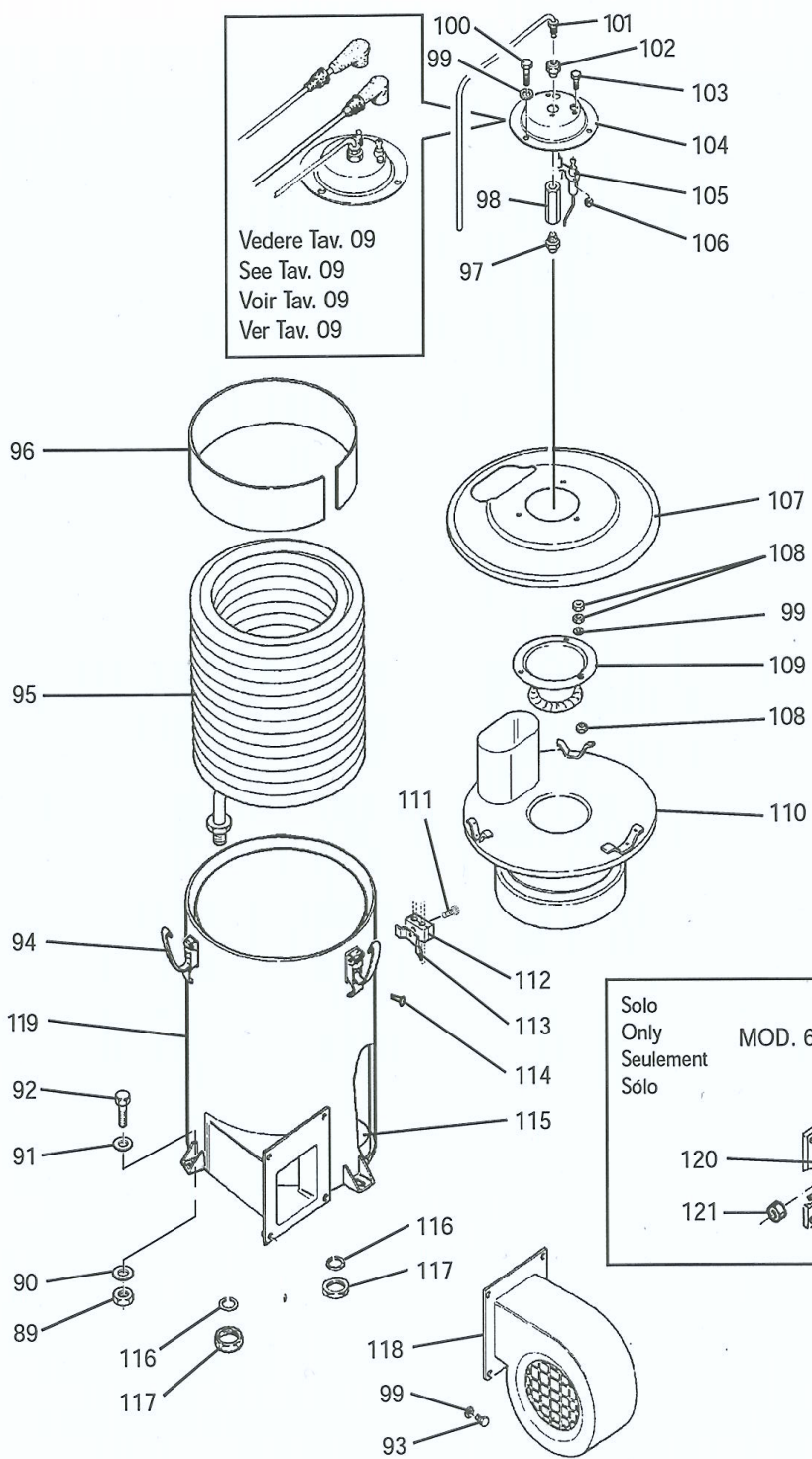

Vedere Tav. 09
See Tav. 09
Voir Tav. 09
Ver Tav. 09

Solo
Only
Seulement
Sólo

MOD. 60 Hz

120
121

Tav. 07

CALDAIA - BOILER - CHAUDIERE - CALDERA

Pos.	Cod.	Note	Q.tà	Desc.	Pos.	Cod.	Note	Q.tà	Desc.
89	1000700		3	Dado Nut Ecrou Tuerca	102	1000230		1	Prolunga Coupling Raccord Empalme
90	1000601		3	Rosetta Washer Rondelle Arandela	103	1000521		2	Vite Screw Vis Tornillo
91	1000600		3	Rosetta Washer Rondelle Arandela	104	3000040		1	Coperchio p.elettrodo Cover Couvercle Tapa
92	1000500		3	Vite Screw Vis Tornillo	105	2000007		1	Elettrodo doppio Electrodes Electrodes Electrodos
93	1000510		4	Vite Screw Vis Tornillo	106	1000740		2	Dado Nut Ecrou Tuerca
94	1000050		4	Gancio di chiusura Hook Crochet de fermeture Gancho de cierre	107	3000030		1	Testata superiore Upper top cover Tete superieure Cabeza superior
95	3000065		1	Serpentina Heating coil Serpentin Serpentín	108	1000750		9	Dado Nut Ecrou Tuerca
96	3100060		1	Anello Ring Collier Anillo	109	3000050		1	Deflettore Deflector Deflecteur Deflector
97	1000100		1	Ugello gasolio Gasoil nozzle Injecteur gas oil Pulverizador gas oil	110	3000020		1	Testata inferiore Lower top cover Tete inferieure Cabeza inferior
98	1000220		1	Portaugello Nozzle carrier Porte injecteur Porta pulverizador	111	1000529		1	Vite autofilettante Cutting screw Vis taraudeuse tornillo autoroscante
99	1000645		10	Rosetta Washer Rondelle Arandela	112	4000029		1	Collare doppio Clamp Borne Abrazadera
100	1000512		3	Vite Screw Vis Tornillo	113	1000088		1	Staffa Bracket Etrier Estribo
101	1000140		1	Tubo gasolio Gasoil pipe Tuyau gasoil Tubo gas oil	114	1000080		1	Rivetto Rivet Rivet Remache